

## TABLES ANDORRA

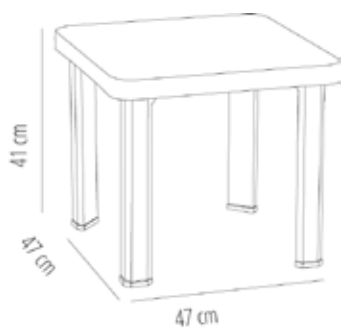

### CERTIFICATIONS

UNE-EN 581-3

### TABLES ANDORRA

Polypropylene side table. UV Protection. Pressure-fitted legs. Net weight 2,14 kg (4.71 lb).

#### TABLE FEATURES

**W** 47cm x **L** 47cm x **H** 41cm

**W** 18.51in x **L** 18.51in x **H** 16.15in

**Weight** 2,14 Kg.

STD units	Packaging dim. (cm)	Units Container 20'	Units Container 40'	Units Container HC	Units Trayler 70m <sup>3</sup>	Units Truck 100m <sup>3</sup>
6X	48 x 52 x 48		2400		3984	

#### TABLETOP

	Anthracite	White	Dark green
47x47cm	●	○	●